

HILTI

Hilti X-HVB system
Solutions for shear
connections



Content page

1. Executive summary	3
1.1. Introduction	3
1.2. Hilti X-HVB shear connector at a glance	4
1.3. Composite beam design	5
1.4. Types of shear connectors	7
2. Hilti X-HVB system	8
2.1. Introduction to the X-HVB	8
2.2. Approvals	8
2.3. Hilti shear connector and X-ENP-21 HVB nails	9
2.4. Material specifications	10
2.5. Application requirements	10
2.6. Tools	10
2.7. Cartridges	11
2.8. Fastening quality assurance	11
3. Applications and value propositions	12
3.1. Value propositions in new construction projects	12
3.2. Value propositions in rehabilitation projects	12
4. Shear connector design according to EC4	13
4.1. Load-displacement behavior of the X-HVB (ductility requirements)	13
4.2. Concrete cover	14
4.3. Distribution of shear connectors on beams	15
4.4. Longitudinal shear force between the concrete slab and the top flange of the steel beam	15
4.5. Shear resistance of X-HVB as per DFTM	16
4.6. Substituting welded shear studs with the X-HVB in design	18
5. X-HVB positioning, spacing and edge distances ...	20
5.1. General rules	20
5.2. Solid concrete slab without steel decking	20
5.3. Concrete slab with steel decking – ribs parallel to beam	21
5.4. Concrete slab with steel decking – ribs transverse to beam	22
5.5. Examples of commercial steel decks	24
6. Design example	31
6.1. Hilti support	32
7. Special considerations	33
7.1. Fire resistance	33
7.2. Rehabilitation	34
7.3. Deflection control	34
8. Project references	35
9. References	36
9.1. Approvals	36
9.2. Direct Fastening Technology Manual	36
10. Literature and Hilti publications	37

1. Executive summary

1.1 Introduction

Traditionally, in composite construction, shear connectors are welded to steel beams. Hilti X-HVB shear connectors, on the other hand, are directly fastened to steel beams with two X-ENP-21 HVB nails per shear connector and require no welding.

The information provided in this document applies to composite beam design in building construction.

The purpose of the X-HVB shear connector is to ensure mechanical connection between steel beams and concrete slabs. It is therefore designed to resist shear forces acting between these structural elements, promoting composite behavior.

This document is intended as a guide to the use of the Hilti X-HVB shear connector. It shows how the calculations are made and covers the following topics:

- Characteristics of the X-HVB shear connector system.
- Resistance of X-HVB in composite beams subjected to bending.
- Layout of shear connectors.
- Provisions for fire resistance.
- X-HVB in rehabilitation.

The information in this document is in accordance with European Regulations.

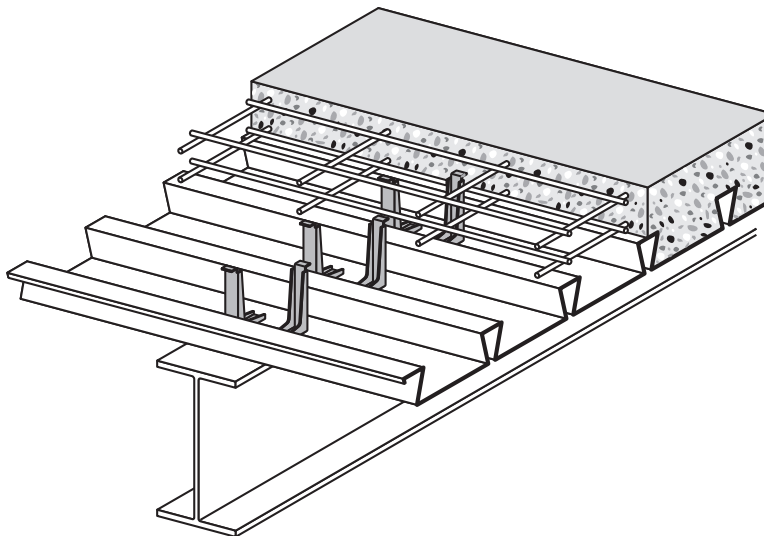

Figure 1: Composite beam with X-HVB shear connector

1.2 Hilti X-HVB shear connector at a glance

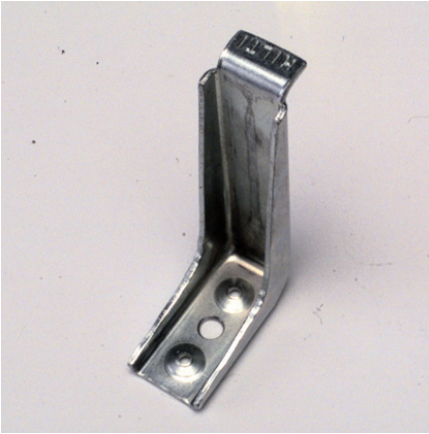

Figure 2: X-HVB shear connector

The X-HVB is a ductile shear connector in accordance with EC4 provisions. It may thus be used to design elastic or plastic shear connections.



Figure 3: X-HVB shear connector with composite decking

Composite beams with or without steel decking

X-HVB is used to effectively transfer longitudinal shear forces between concrete slabs and steel beams.

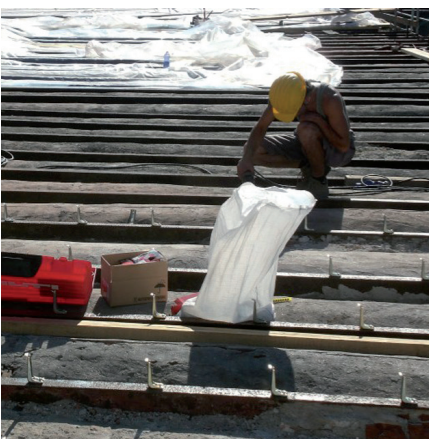

Figure 4: X-HVB shear connector in rehabilitation

Rehabilitation

As each Hilti X-HVB shear connector is fastened to a steel beam with 2 nails, it is also suitable for installation on wrought iron and coated/painted beams. This promotes composite behavior between existing steel elements and new concrete layers, increasing allowable loads in existing buildings.

Quick and easy to install – independent of site conditions

As no welding and therefore no electric power is required, the X-HVB can be installed in damp conditions, where welding may be unreliable.

1.3 Composite beam design

Cast-in-place concrete slabs supported by steel beams can be designed as composite or non-composite structures.

In other words, the steel beams supporting the concrete slab can be designed separately from the slab (**Figure 5-A**) or, alternatively, these structural components can be designed to act together as a single element that resists bending, i.e. making use of composite design. (**Figure 5 – B & C**).

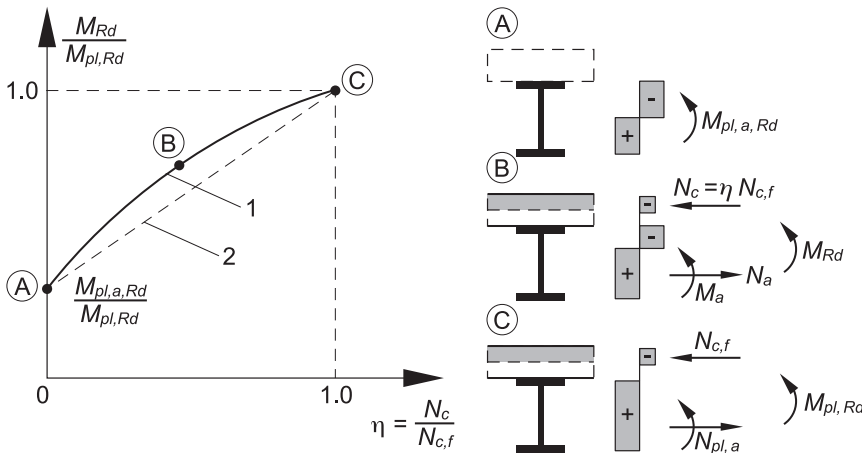

Figure 5: Degrees of shear connection, assuming plastic characteristics

In composite design (**Figure 5 – B & C**), shear connectors must be installed on the top flange of steel beams and are responsible for the transfer of longitudinal shear stress across the interface between steel and concrete.

When slip occurs at the interface it is accompanied by simultaneous vertical displacement of the concrete. Shear connectors must therefore also be able to resist this displacement and thus prevent vertical uplift.

Full composite action is achieved when

- the full shear capacity of the steel or concrete can be utilized, i.e. the shear connection does not control the capacity of the composite beam
- and slip between the structural elements is negligible.

In cases where full composite action is not required, e.g. for limitation of deflection, the concept of partial shear connection is introduced,

- with limited slip at the interface
- and bending resistance is controlled by the degree of shear connection.

Since partial shear connection does not allow the full bending resistance of the cross-sections to be achieved, there are limitations regarding bending resistance with partial shear connection, which are further addressed in this document and fully in EC4 and EC8.

Composite beam design is especially suitable for cross-sections under positive bending moments, as concrete has good resistance to compression.

If steel decking is used, the decking's resistance to compression should be neglected.

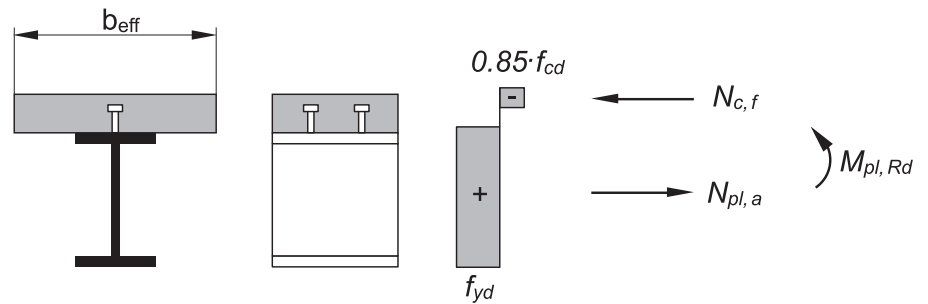

Figure 6: Example of plastic stress distribution for a composite beam with a solid slab and a full shear connection (positive bending moment)

Continuity of the beam can also create negative bending moments near supports. For negative bending moments, the slab's reinforcement is in tension and shear connectors must ensure that tensile force in the reinforcement is transmitted to the steel beam. When a profiled deck is used, it is assumed to be stressed to its design yield strength.

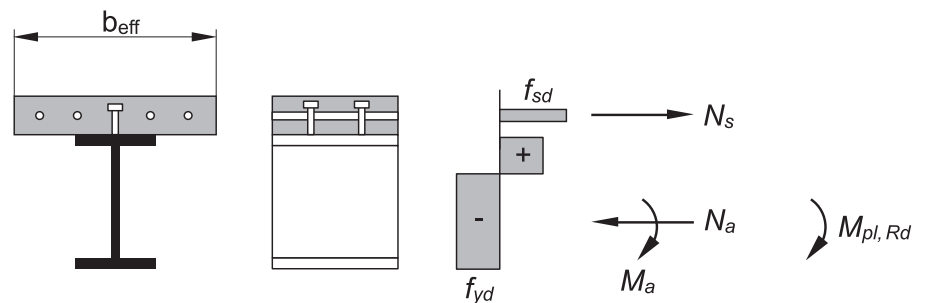

Figure 7: Example of plastic stress distribution for a composite beam with a solid slab and a full shear connection (negative bending moment).

Since the composite member cross-section is larger than the beam's cross-section alone, the respective moment of inertia is higher, resulting in higher resistance to bending. These considerations allow for slimmer design of structural components. The main benefits related to composite beam design are therefore related to the fact that use of a composite section allows for savings in material and space.

In modern construction, steel decking is used as permanent formwork for the concrete slab and as reinforcement for the composite deck. The decking is utilized to limit the amount of slab propping during construction.

1.4 Types of shear connectors

1.4.1 Welded shear studs

Welded shear studs are the most common and traditional type of shear connectors. Typically, welded shear studs exhibit ductile behavior and have good resistance to horizontal shear and vertical uplift:

- Horizontal shear is resisted by the shank.
- Vertical uplift is prevented by the head.

When steel decking is used, either the studs are welded through the decking or the decking perforated and pre-welded studs fitted through the perforations.

Inherent concerns related to welding are as follows:

- Welding requires skilled/experienced labor.
- Quality control checks may be ambiguous, i.e. visual inspection, sound produced when hammered, bending test.
- Equipment required on site, resulting in transportation costs and effort.
- Numerous electric cables required, which may lead to tripping hazards.
- Welding quality is largely dependent on beam surface conditions, i.e. humidity, rust, etc.
- Welds on wrought iron beams might be brittle and not effective.
- Direct welding onto galvanized beams may cause health issues.
- Finishing work is necessary after welding on coated/painted beams.
- Sites with fire regulations (fire watch) may restrict hot works, i.e. welding.

1.4.2 Hilti X-HVB shear connector

The Hilti X-HVB shear connector is an L-shaped shear connector which is fastened onto a beam with two nails driven by a powder-actuated tool.

The X-HVB is ductile and designed to resist

- longitudinal shear force through nail hole elongation,
- and vertical uplift which is prevented by the head and the nails.

It is suitable for use at the connection between concrete slabs and steel beams with or without steel decking. As the X-HVB is fastened with Hilti direct fastening technology, it is versatile enough to be used in situations where welded studs are not applicable and/or not effective.

The X-HVB system does not require electric power, has an easy and approved inspection procedure and, unlike welding, it is not weather dependent and does not infringe site hot works, i.e. fire-watch, regulations. X-HVB placement is also not sensitive to the beams' surface treatment.

Typical features of the X-HVB are:

- simple, inexpensive installation equipment,
- fastening quality largely independent of weather conditions,
- fast installation allows flexible scheduling of work on the jobsite,
- zinc coatings or moisture do not affect the fastening quality.

When retrofitting/renovating older buildings, i.e. rehabilitation projects, the X-HVB is fastened to existing wrought iron beams that will support newly cast slabs. This method is used in flooring systems for rehabilitation purposes, mostly subjected to static loading.

The main advantages of using the rehabilitation technique are

- the increase in bending resistance,
- decrease in deformability/deflection

and hence the ability to adapt structures to modern load requirements and usage.



Figure 8: Headed studs welded through profile decks



Figure 9: Hilti X-HVB installed in profile deck

2. Hilti X-HVB system

2.1 Introduction to the X-HVB

The X-HVB system is an effective and efficient solution for secure shear connection. Direct fastening technology makes this shear connector easy to install since it can be set securely and reliably by workmen with simple training.

Hilti X-HVB shear connectors are fastened to steel components, typically the top flange of a steel beam, using a Hilti DX 76 or DX 76 PTR tool equipped with accessories specifically for this purpose.

The nail-driving energy is provided by Hilti DX cartridges (powder-actuated system).

As no welding is required, the X-HVB system can be installed under almost any site conditions. In addition, fastening quality assurance is provided by an easy and approved inspection process.

The system comprises the following items:

Hilti shear connector (Figure 10):

- X-HVB shear connector, available in different heights.
- Two X-ENP-21 HVB nails for each X-HVB shear connector.

Fastening tools and equipment:

- DX 76 or DX 76 PTR tool (Figure 11)
- X-76-F-HVB or X-76-F-HVB-PTR fastener guides
- X-76-P-HVB or X-76-P-HVB-PTR piston
- 6.8/18M cartridges, black or red (Figure 12)



Figure 10: Hilti X-HVB shear connector with two X-ENP-21 HVB nails



Figure 11: Hilti DX 76 PTR tool, equipped for X-HVB installation

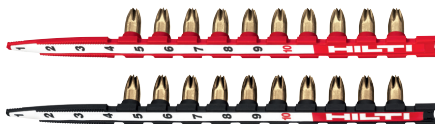

Figure 12: Red and black cartridges

2.2. Approvals

Several approvals have been awarded to the X-HVB system (Table 1) and the system is compliant with EN1994-1-1.

Socotec PX 0091/7	France
Socotec PX 0091/8	France
DIBt Z-26.4-46	Germany
TZUS 070-041312	Czech Republic
Rom.Ministry_AT 016-01/281-2013	Romania

Table 1: List of approvals

The German DIBt Z-26.4-46 approval addresses fire design as per EN1994-1-2 and the French Socotec PX 0091/8 approval specifically prescribes the use of X-HVB for rehabilitation purposes.

Approvals are subject to continuous changes related to code developments, product portfolio updates and new research results. Current approvals can be downloaded from the Hilti website or from the websites of most certification bodies.

2.3 Hilti shear connector and X-ENP-21 HVB nails

The L-shaped shear connectors are cold formed from steel and comprise the fastening leg, the anchorage leg and the head. The anchorage leg is cast into the concrete while the fastening leg is fastened to the steel beam with two X-ENP-21 HVB nails (Figure 13).

The shear connectors are available in 6 different anchorage leg heights for different steel decking and slab configurations (detailed geometry in Figure 14):

Designation	Item number
X-HVB 50	56467
X-HVB 80	239357
X-HVB 95	348179
X-HVB 110	348180
X-HVB 125	348181
X-HVB 140	348321
Each connector fastened with two nails:	
X-ENP-21 HVB	283512

Table 2: X-HVB designations and respective item number

Note: The number following X-HVB indicates the approximate height of the shear connector in millimeters.

Note: The Hilti X-HVB 50 is used specifically for thin slabs without steel decking in rehabilitation projects.

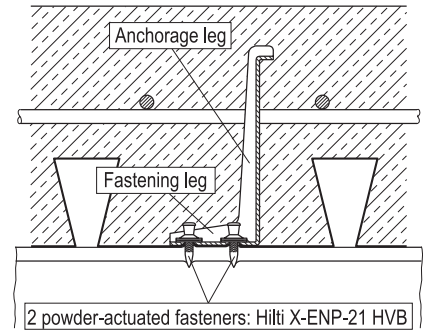
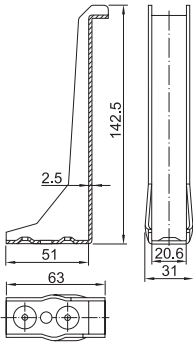
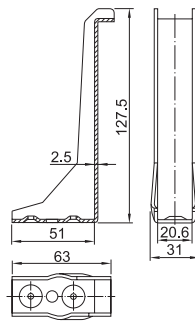

Figure 13: Shear connection in composite beams

X-HVB 140



X-HVB 125



X-HVB 110

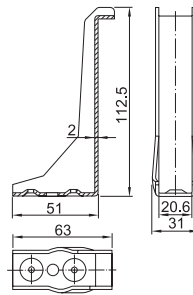

X-HVB 95

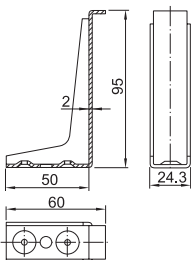

X-HVB 80

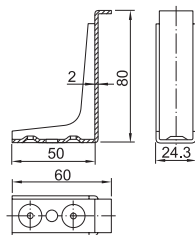

X-HVB 50

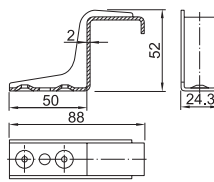

Figure 14: Detailed geometry of X-HVB

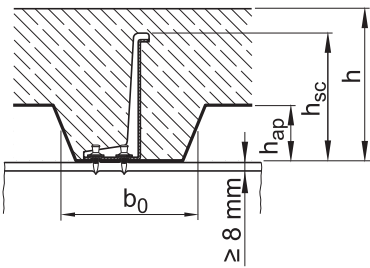

Figure 15: Minimum thickness of steel base material

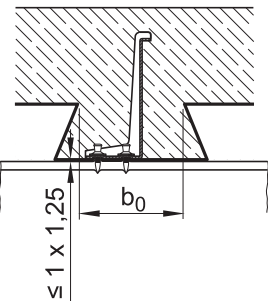

Figure 16: Maximum thickness of deck



Figure 17: DX 76 for X-HVB installation

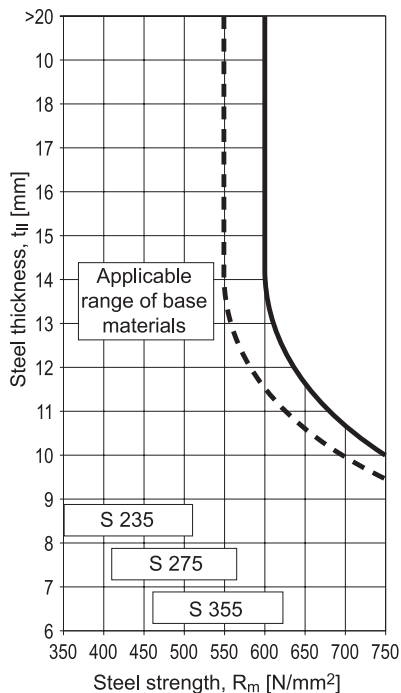

Figure 18: Application limit

2.4 Material specifications

X-HVB shear connector

Carbon steel	$R_m=295-350\text{N/mm}^2$
Zinc coating	$\geq 3 \mu\text{m}$

X-ENP-21 HVB nails

Carbon steel shank	HRC58
Zinc coating	8-16 μm

2.5 Application requirements

Thickness of steel base material (beam flange) $\geq 8 \text{ mm}$.
 Thickness of fastened material (steel decking) $\leq 1.25 \text{ mm}$.

Please refer to the DIBt and Socotec approvals for detailed information on decking thicknesses and overlaps.

Details of connector positioning, spacing and edge distances can be found in **Section 5: X-HVB positioning, spacing and edge distances.**

2.6 Tools

The tools used to drive the nails into the steel are the DX 76 and the DX 76 PTR. Figure 17 shows the DX 76 tool for X-HVB installation.

Tool	Equipment	Name	Item no.
DX 76	Tool	DX 76 MX	285789
DX 76	Piston	X-76-P-HVB	285493
DX 76	Fastener guide	X-76-F-HVB	285486
DX 76 PTR	Tool	DX 76 PTR	384004
DX 76 PTR	Piston	X-76-P-HVB-PTR	388847
DX 76 PTR	Fastener guide	X-76-F-HVB-PTR	388846

Table 3: Designation of tool components for fastening the X-HVB



Figure 19: DX 76 tool



Figure 22: DX 76 PTR tool



Figure 20: X-HVB piston for DX 76



Figure 23: X-HVB piston for DX 76 PTR



Figure 21: X-HVB fastener guide for DX 76



Figure 24: X-HVB fastener guide for DX 76 PTR

2.7 Cartridges

The DX 76 and DX 76 PTR tools use 6.8/18M black or red cartridges which are supplied in strips of 10.

Selection of the cartridges is dependent on steel beam (base material) strength and thickness (Figure 25).

The blue cartridge may also be used in rehabilitation applications. Please refer to the French Socotec PX 0091/8 approval for details.

Based on the cartridge recommendations, fine adjustments can be made by carrying out nail-driving tests on site. If nail standoff lies between 8.2 and 9.8 mm after the nail is driven, the cartridge and the tool power settings are considered appropriate for the base material.

Table 4 provides information regarding cartridges relevant for X-HVB fastening.

Size	Color code	Power level	Item no.
6.8/18 M10 STD	Red	Medium high	416484
6.8/18 M10 STD	Black	Extra high	416486
6.8/18 M10 STD	Blue	Medium	416485
6.8/18 M10	Red	Medium high	50602
6.8/18 M10	Black	Extra high	50603
6.8/18 M10	Blue	Medium	50611

Table 4: Cartridges for X-HVB placement

2.8 Fastening quality assurance

Fastening Inspection:

The primary means of checking the quality of the nail fastening to the supporting beam is a visual check of nail standoff (Figure 26).

The visual appearance of the top washer and the nail standoff h_{NVS} indicate how the tool power setting should be adjusted (Table 5).

Visual appearance	Corresponding nail standoff, h_{NVS} [mm]	Adjustment required
Visible damage to top washer	$h_{NVS} < 8.2$	Reduce power setting or use lighter cartridge
Light or no piston imprint on top washer	$8.2 < h_{NVS} < 9.8$	No adjustment: Cartridge and power setting are correct
Visible gap between top and bottom washer	$h_{NVS} > 9.8$	Increase power setting or use heavier cartridge

Table 5: Fastening inspection and nail standoff

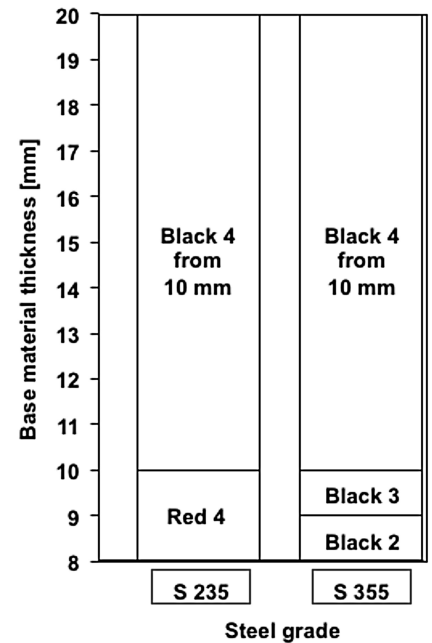

Figure 25: Cartridge pre-selection and power settings

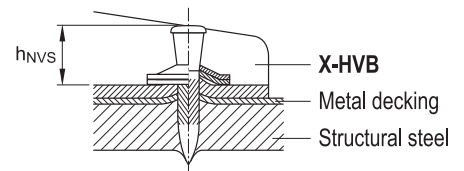

Figure 26: Nail standoff for the X-ENP-21 HVB nail

3. Applications and value propositions

3.1 Value propositions in new construction projects

- Does not infringe site hot works, i.e. fire-watch, regulations.
- Easy and approved inspection method.
- Avoids pre-punching of steel decking which enables longer spans and less propping.
- Can be installed on coated and painted beams without need for subsequent finishing.
- Does not require use of welding equipment and generators, i.e. no equipment transportation to/from and on site.
- Installation quality is independent of site conditions, i.e. moisture after rain, light surface rust, etc.

Hence, the X-HVB system is therefore the ideal solution in situations

- where large numbers of welded shear studs are pre-welded on primary beams in the yard/shop (ideal welding conditions) and smaller numbers of shear connectors are required to be installed on site using the direct fastening method, i.e. on secondary beams.
- with limited transportation and crane access.
- in remote areas.

3.2 Value propositions in rehabilitation projects

The value propositions for new construction projects (as mentioned above) also make the X-HVB system particularly cost-effective in rehabilitation projects.

- In very thin slabs, the X-HVB 50 may be used where there is no steel decking (**Figure 27**).
- Can be fastened to traditional, wrought iron beams where welding is not possible.



Figure 27: Floor to be strengthened with thin concrete layer

4. Shear connector design according to EC4

4.1 Load-displacement behavior of the X-HVB (ductility requirements)

According to EN1994-1-1 section 6.6.1.1 (5), a shear connector may be considered ductile if the characteristic slip capacity δ_{uk} is 6 mm or more.

The ductility of a shear connection is tested with push-out tests as defined in EN1994-1-1 section B2 guidelines.

The X-HVB is tested with similar a setup as similar to that shown in **Figure 28**.

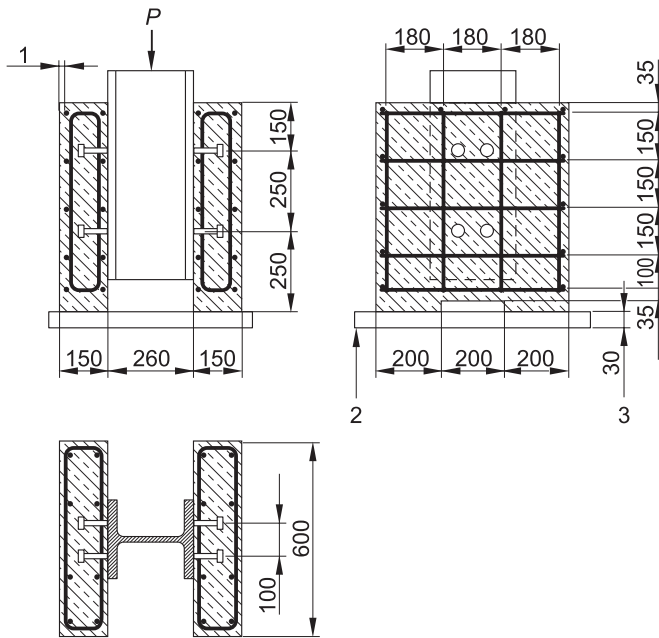

Figure 28: Push out test setup according to EN 1994-1-1



Figure 29: Push-out test with X-HVB

Figure 30 shows examples of the load-displacement diagrams obtained from these push-out tests.

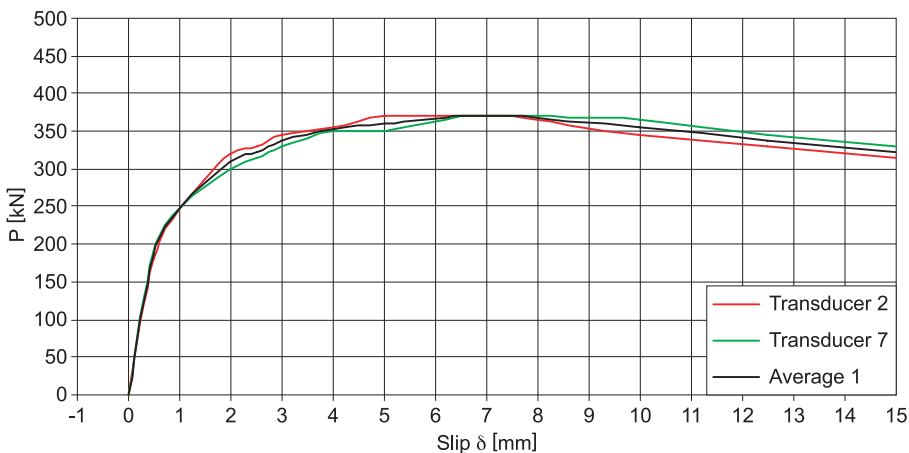

Figure 30: Load-displacement curve for push-out tests

Test results have shown that Hilti X-HVB shear connectors are ductile and meet the Eurocode 4 requirements for connections with plastic properties.

The connector's ductile load-bearing characteristics are ensured by design provisions, such as mentioned in:

- **Section 2.5. Application requirements**
- **Section 4.5. Shear resistance of X-HVB as per DFTM (Table 8)**
- **Section 5. X-HVB positioning, spacing and edge distances**

Where plastic stress distribution is taken into account in the beams, Eurocode 4 allows partial shear connection limited to 0.4 to be taken into account. The degree of shear connection is calculated as follows:

$$\eta = \frac{N_c}{N_{c,f}}$$

Where

- N_c is the resistance of the shear connection.
- $N_{c,f}$ is the design value of the compressive normal force in the concrete flange with full shear connection.

4.2 Concrete cover

EN1994-1-1, section 6.6.5.2, identifies elements with risk of corrosion and elements which are not exposed to corrosion.

EN1992-1-1, table 4.4, specifies that if concrete cover is required (exposure class as identified in EN1994-1-1 section 6.6.5.2), the nominal concrete cover

- can be 5 mm less than the values in EN1992-1-1, table 4.4.
- not less than 20 mm.

If no concrete cover is required, the code allows for the top of the connector to be flush with the top of the concrete slab.

Table 6 lists the recommended total slab thicknesses for the different X-HVBs. For more details, please refer to relevant Socotec and DIBt approvals.

Connector	Total slab thickness, h [mm]	
	No risk of corrosion	Risk of corrosion
X-HVB 80	80*/90	100
X-HVB 95	95	115
X-HVB 110	110	130
X-HVB 125	125	145
X-HVB 140	140	160

Table 6: Recommended total slab thickness, Socotec and DIBt

*DIBt recommendation only.

4.3 Distribution of shear connectors on beams

Elastic – If the beam is considered to behave elastically, shear connectors are distributed along the beam according to shear loads, i.e. higher shear loads near the supports or concentrated load are resisted by closer spacing of shear connectors. Such distribution ensures that each connector carries an equal share of the longitudinal shear force acting on the beam (**Figure 31**).

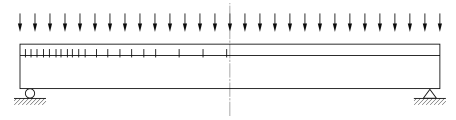

Figure 31: Graduated distribution of shear connectors

Plastic – When beams are designed to the ultimate limit state and carry uniform loads, the shear connectors are spaced and distributed equally and uniformly along the beam, as the load is redistributed by the shear connectors. The shear connector used must fulfill the ductility requirements of the applicable section of Eurocode 4 – see **section 4.1 Load-displacement behavior of the X-HVB (ductility requirements)**.

4.4 Longitudinal shear force between the concrete slab and the top flange of the steel beam

Shear connectors are designed to resist the longitudinal shear forces (as per stress distribution of the cross sections) in the horizontal plane between the concrete slab and top flange of the steel beam.

Typical plastic stress distributions are displayed in **Figure 32**.

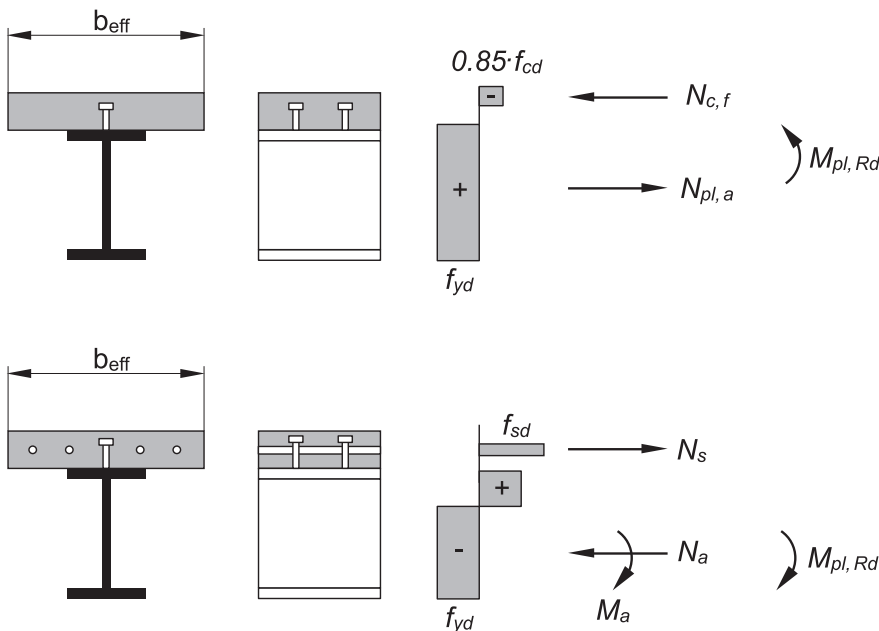

Figure 32: Typical plastic stress distributions for positive and negative bending moments

In full shear connection, the total shear resistance of shear connectors used must be equal to or greater than the total designed longitudinal shear force of the beam in ultimate limit state.

Therefore, in full shear connection, the number of shear connectors to be used is determined by

$$\frac{\text{Designed longitudinal shear force of beam (ultimate limit state)}}{\text{Shear resistance of each shear connector}}$$

4.5 Shear resistance of X-HVB as per DFTM

The loadbearing capacity of the X-HVB, i.e. shear resistance in a solid concrete slab, is the combined result of

- hole elongation in the fastening leg of the connector,
- local deformation of the base steel plus bending of the nails,
- bending of the X-HVB
- and local deformation of concrete in the contact zone with the connector.

4.5.1 Shear resistance of X-HVB in slab without steel decking

The shear resistance of the X-HVB is calculated with reference to recommendations in the Direct Fastening Technology Manual, and based on EN1994-1-1.

For slabs without steel decking, the shear resistance of the X-HVB shear connector is as follows (**Table 7**).

Nominal	Characteristic shear resistance ¹⁾	Design shear resistance ²⁾	Allowable horizontal shear ³⁾
X-HVB 50	23 kN	18 kN	N. A.
X-HVB 80	28 kN	23 kN	14 kN
X-HVB 95	35 kN	28 kN	17.5 kN
X-HVB 110	35 kN	28 kN	17.5 kN
X-HVB 125	35 kN	28 kN	17.5 kN
X-HVB 140	35 kN	28 kN	17.5 kN

Table 7: Design shear resistance of the X-HVB

¹⁾ As defined in EN1994-1-1 (nominal strength in AISC-LRFD)

²⁾ As defined in EN 1994-1-1

³⁾ Allowable shear in AISC-ASD

4.5.2 Shear resistance of the X-HVB in slab with steel decking

When profile steel decking is present, the shear resistance of the X-HVB is calculated by multiplying the shear resistance without steel decking with reduction factors that are dependent on decking orientation and profile geometry.

Steel decking with ribs parallel to supporting beam – Design shear resistance of each X-HVB is design shear resistance in **Table 5** multiplied by reduction factor k_p or k_r , (≤ 1) where

$$k_p = \begin{cases} 1 & , \text{for } \frac{b_o}{h_p} \geq 1,8 \\ 0,6 \frac{b_o}{h_p} \frac{h_{sc} - h_p}{h_p} & , \text{for } \frac{b_o}{h_p} < 1,8 \end{cases}$$

Please refer to **Figure 33** for profile geometries.

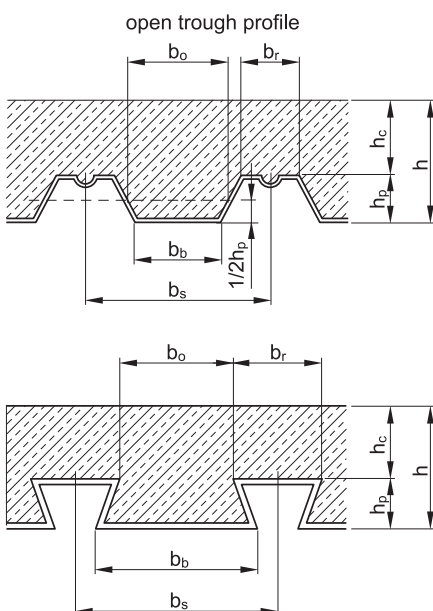

Figure 33: Steel decking profile geometries

Steel decking with ribs transverse to supporting beam – When the ribs are transverse to the supporting beam, the shear resistance of each X-HVB is influenced by reduction factor, k_t .

$$k_t = \frac{0,7 b_o}{\sqrt{n_r} h_p} \left(\frac{h_{sc} - h_p}{h_p} \right) \leq 1$$

Where,

b_o is the width of the steel decking profile

h_p is the height of the steel decking profile

h_{sc} is the height of the X-HVB

n_r is the number of X-HVBs per rib, ≤ 2 even when more X-HVBs are installed in a rib.

Fastener selection with regard to the profile deck

The maximum allowable steel decking height is as per **Table 6** is shown below.

Designation	Maximum decking height, h_p (mm)	
	$b_o / h_p \geq 1,8$	$b_o / h_p < 1,8$
X-HVB 80	45	45
X-HVB 95	69	57
X-HVB 110	75	66
X-HVB 125	80	75
X-HVB 140	80	80

Table 8: Maximum decking heights, according to DFTM

Note: The X-HVB 50 is not to be used with profiled steel decking.

4.6 Substituting welded shear studs with the X-HVB in design

Shear resistance of headed studs in slabs without steel decking

Section 6.6.3.1 of EN1994-1-1 states that the design resistance of a headed stud, automatically welded to a steel beam, should be the lesser value of:

$$P_{Rd} = \frac{0,8f_u \pi d^2 / 4}{\gamma_v}$$

$$P_{Rd} = \frac{0,29 \alpha d^2 \sqrt{f_{ck} E_{cm}}}{\gamma_v}$$

Where,

$$\alpha = 0,2 \left(\frac{h_{sc}}{d} + 1 \right) \text{ for } 3 \leq h_{sc}/d \leq 4$$

$$\alpha = 1 \text{ for } h_{sc}/d > 4$$

γ_v is the partial safety factor (recommended value = 1.25)

d is the diameter of the stud shank.

f_u is the specified ultimate tensile strength of the stud material but not greater than 500 N/mm².

h_{sc} is the overall nominal height of the stud.

Shear resistance of welded studs in slab with profiled steel decking

When profiled steel decking is used, the shear resistance of the welded stud is calculated by multiplying **the shear resistance without steel decking by reduction factors that are dependent on decking orientation and profiles.**

These reduction factors may significantly reduce shear resistance.

Steel decking with ribs parallel to supporting beam - the reduction factor k_1 is:

$$k_1 = 0,6 \frac{b_o}{h_p} \left(\frac{h_{sc}}{h_p} - 1 \right) \leq 1$$

Where,

$$h_{sc} \leq h_p + 75 \text{ mm}$$

Steel decking with ribs transverse to supporting beam - The values of reduction factor k_t are governed by **Table 9** (Table 6.2 of EC4) and the following equation:

$$k_t = \frac{0,7 b_o}{\sqrt{n_r} h_p} \left(\frac{h_{sc}}{h_p} - 1 \right) \leq 1$$

Where,

n_r is the number of welded studs per rib, not exceeding 2.

Number of stud connectors per rib	Thickness t of sheet (mm)	Sheet with holes exceeding 20 mm in diameter and welded through profiled steel sheeting	Profiled sheeting with holes and studs 19 mm or 22 mm in diameter
$n_r = 1$	≤ 1.0	0.85	0.75
	≥ 1.0	1.0	0.75
$n_r = 2$	≤ 1.0	0.7	0.6
	≥ 1.0	0.8	0.6

Table 9: Upper limits for the reduction factor k_t (Table 6.2 of EC4)

Comparison of the applicable design values between X-HVBs and headed studs shows that the headed studs clearly lose ground to X-HVBs when profile decks are used, as allowance must be made for a reduction in loading capacity when perforated sheets are used or when studs are welded through the sheets.

With nailed shear connectors, however, the method results in no loss of loading capacity. Table 10 shows an example for comparison.

Means of shear connection	P_{Rd} [kN]		
	Solid slab	Composite slab	
		Perforated steel deck	Steel deck with studs welded through or with driven nails
Headed studs $d=19$ mm ¹⁾	70.6	42.4	49.4
Shear connectors X-HVB 125	28.0	28.0	28.0

¹⁾ Where $\alpha = 1$, $n_r = 2$, $t \leq 1$

Table 10: Comparison of the maximum design values for headed studs and X-HVB nailed shear connectors for C30/37

When comparing the designed shear resistances of both welded shear studs and the X-HVB, the number of X-HVB required to substitute welded shear studs can be determined by simple division of the respective longitudinal shear resistances.

5. X-HVB positioning, spacing and edgedistances

5.1 General rules

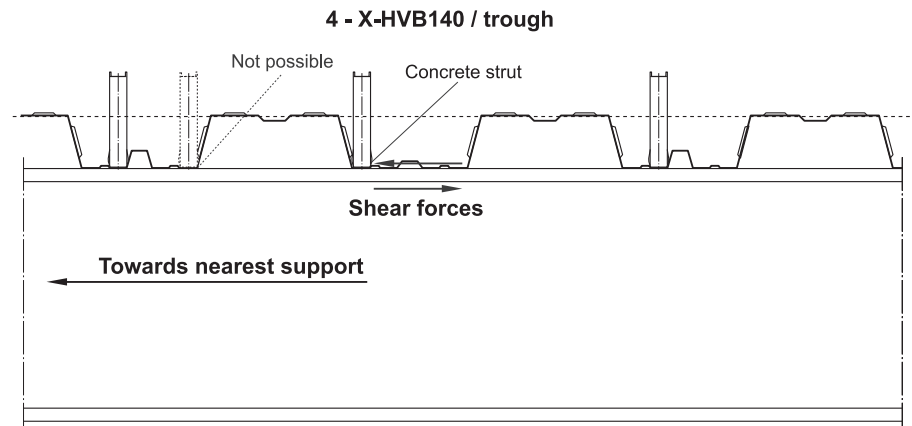

Figure 34: Stress transmission in concrete slab

Load transfer between X-HVB and the slab is accomplished predominantly by a concrete strut, as illustrated in **Figure 34**.

In addition, when steel decking has narrow ribs and/or stiffeners, the X-HVB should be positioned on the favorable side of the rib, which is towards the nearest beam support, as per **Figure 34**, to allow sufficient load transfer.

Positioning the X-HVB in relation to the supporting beam: The X-HVBs may be placed parallel or transverse to the supporting beam. If possible, X-HVB orientation parallel to the axis of the beam is preferred.

Positioning the X-HVB in relation to the decking profile: The X-HVBs may be placed parallel or perpendicular to the profile ribs.

Minimum distance to the edge of the beam: The X-HVBs can be set flush with the edge of the beam flange, if required.

5.2 Solid concrete slab without steel decking

In addition to the rules mentioned previously, the X-HVBs should be placed longitudinally, parallel to the beam, and opposing each other, as shown in **Figure 35** and **Figure 36**. The minimum longitudinal distance between the anchorage legs is 100 mm and the shear connectors must be spaced at a maximum of 4 times the total concrete thickness or 600 mm, whichever is smaller.

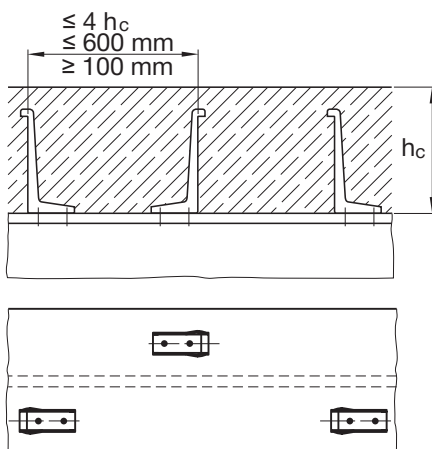

Figure 35: Solid concrete plate with one X-HVB per row

In cases where more than one X-HVB is placed in the same row, the minimum distance between adjacent X-HVBs is 50 mm (**Figure 36** and **Figure 37**).

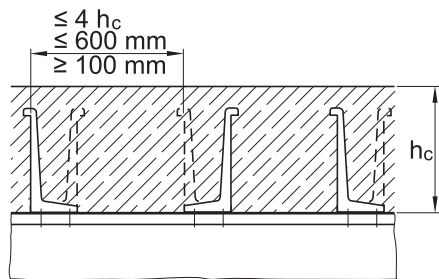

Figure 36: Solid concrete slab with more than one X-HVB in the same row, for concrete slabs without steel decking

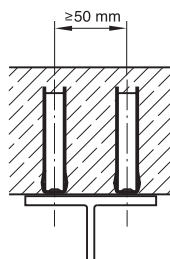

Figure 37: Minimum spacing between shear connectors for concrete slabs without steel decking

5.3 Concrete slab with steel decking - ribs parallel to beam

In general, the ribs of steel decking are parallel to the primary beam. Ideally, the X-HVBs should also be placed parallel to the beam and opposite each other.

When only one X-HVB is placed on the flange it should be centered relative to both the supporting beam and the decking rib and ensure a minimum b_o of 60 mm (**Figure 38**).

However, when profiles have stiffeners between ribs, placement of the X-HVB should alternate between opposite to each other and positions to the left and right of the web (**Figure 39**).

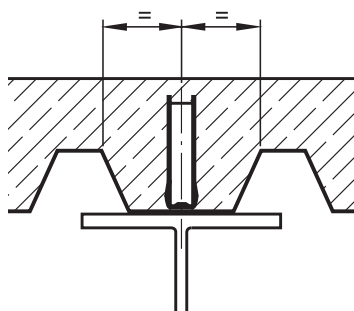

Figure 38: Shear connector centered on the flange

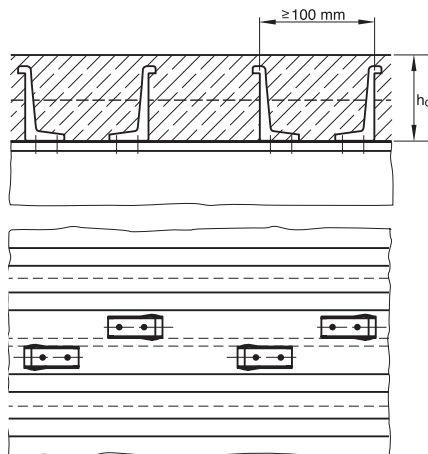

Figure 39: Minimum distance between X-HVBs

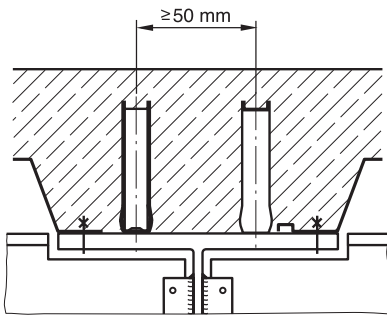

Figure 40: Minimum distance between X-HVBs

When more than one X-HVB is placed parallel on the flange, the minimum distance between the X-HVBs should be 50 mm (Figure 40).

If the dimensions indicated above are not possible, it is recommended that the steel decking on the flange of the beam is separated in order to accommodate X-HVB installation. The steel decking is then fastened to the flange with suitable Hilti fasteners (Figure 40).

When the primary beams are not the same height as the secondary beams, separation of the steel decking is always necessary. The separated steel decking must be directly fastened to the flange with suitable Hilti fasteners. The X-HVBs can be placed between the nails or directly over the beam (Figure 41).

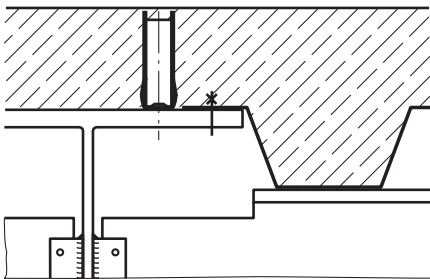

Figure 41: Detail of main beam and secondary beam

5.4 Concrete slab with steel decking - ribs transverse to beam

The shear connector may be placed **parallel** or **transverse** to the supporting beam.

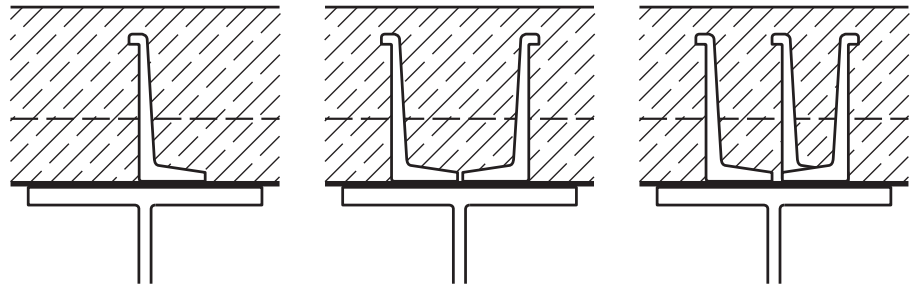

Figure 42: X-HVB perpendicular to supporting beam

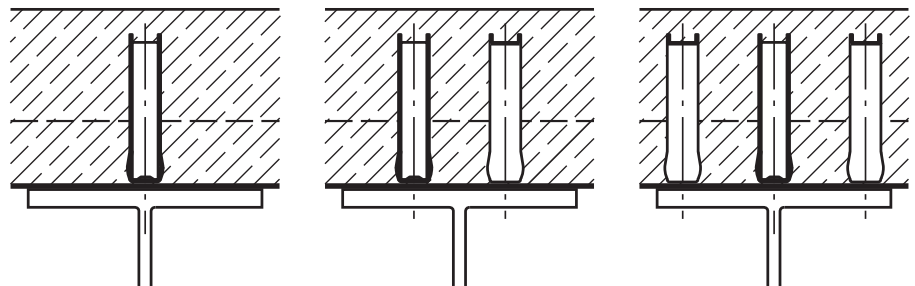

Figure 43: X-HVB parallel to supporting beam

5.4.1 One X-HVB per rib

When the X-HVBs are placed perpendicular to the supporting beam (**Figure 42** and **Figure 44**), the X-HVB should, preferentially, be located at the middle of the valley, as indicated in **Figure 44**.



Figure 44: One X-HVB per rib, perpendicular to the supporting beam

When X-HVBs are placed parallel to the supporting beam, the X-HVB should be placed over the web and the anchorage leg should be centered.

For steel decking with stiffeners, where the X-HVB is perpendicular to the supporting beam (**Figure 46**), it should be placed next to the indents. When the X-HVB is parallel to the supporting beam the anchorage leg should face the indent (**Figure 47**).

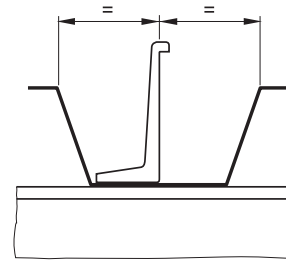

Figure 45: One X-HVB per rib, parallel to supporting beam

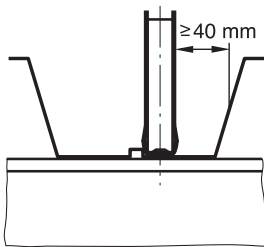

Figure 46: Decking with indentations, X-HVB perpendicular to supporting beam

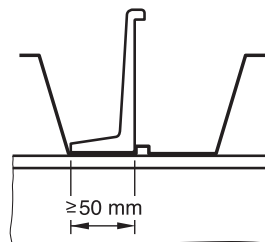

Figure 47: Decking with indentations, X-HVB parallel to supporting beam

5.4.2 Two X-HVBs per rib

The shear connectors must be aligned in the middle of the valley, with the anchorage legs facing outwards (**Figure 48**).



Figure 48: Two shear connectors per rib

The shear connectors should be arranged symmetrical to the beam's central axis (**Figure 48**).

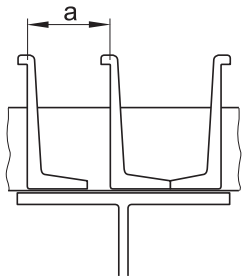

Figure 49: Minimum distance between X-HVB anchorage legs

5.4.3 Three X-HVBs per rib

For X-HVB positioning in decking with ribs transverse to the supporting beam (typically secondary beams), two types of profiled decks can be distinguished according to their b_o / h_p relation. The minimum distance between anchorage legs, governed by this classification, is indicated in **Table 11**.

The X-HVBs placed near the edges of the beams should face the exterior, and the shear connector in the middle should be aligned with the beam's web.

b_o / h_p	a
$b_o / h_p > 1.8$	a > 50mm
$b_o / h_p < 1.8$	a > 100mm

Table 11: Minimum distance, a between X-HVB anchorage legs

Please contact your local Hilti representatives if more than three X-HVB per rib are necessary.

5.5 Examples of commercial steel decks

5.5.1 Holori b HR 51/150

Two X-HVB per rib

Section A-A

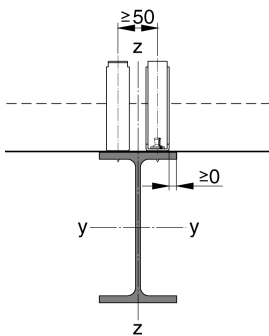

Section B-B

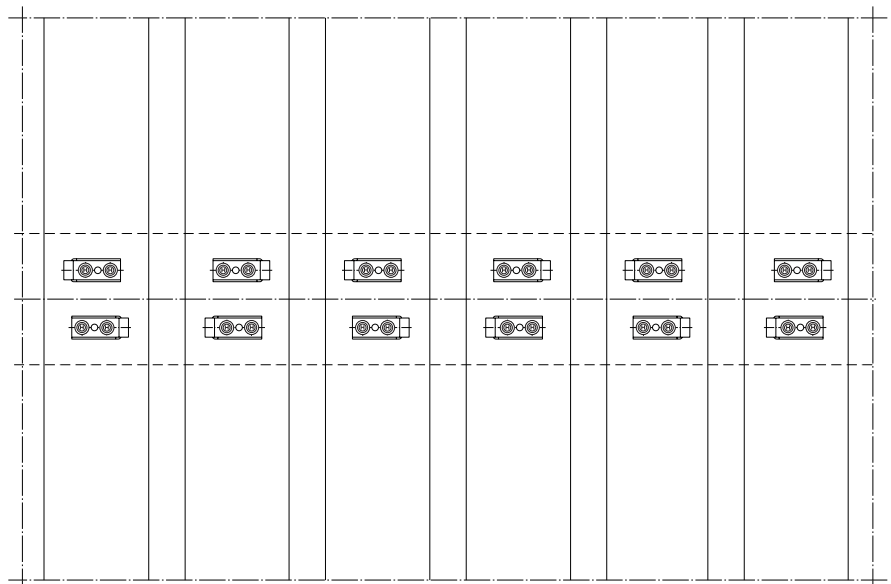
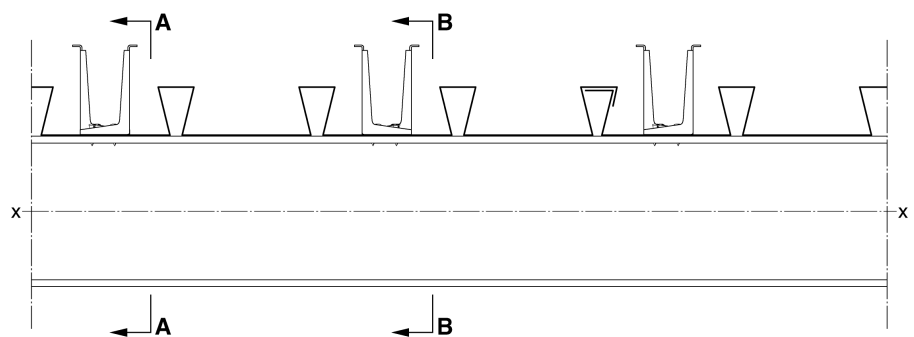
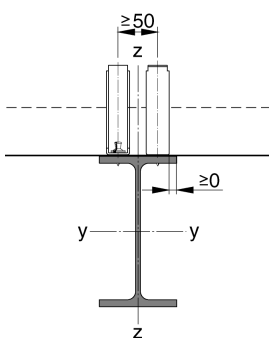

Three X-HVB per rib

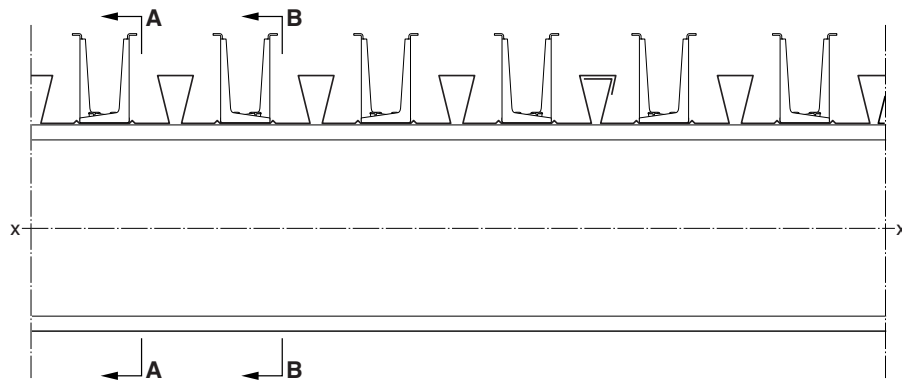

Section A-A

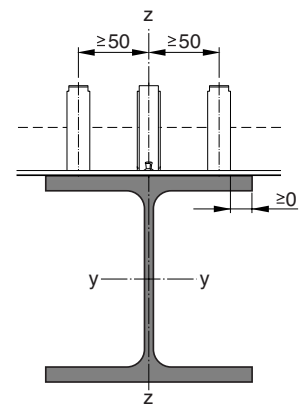

Section B-B

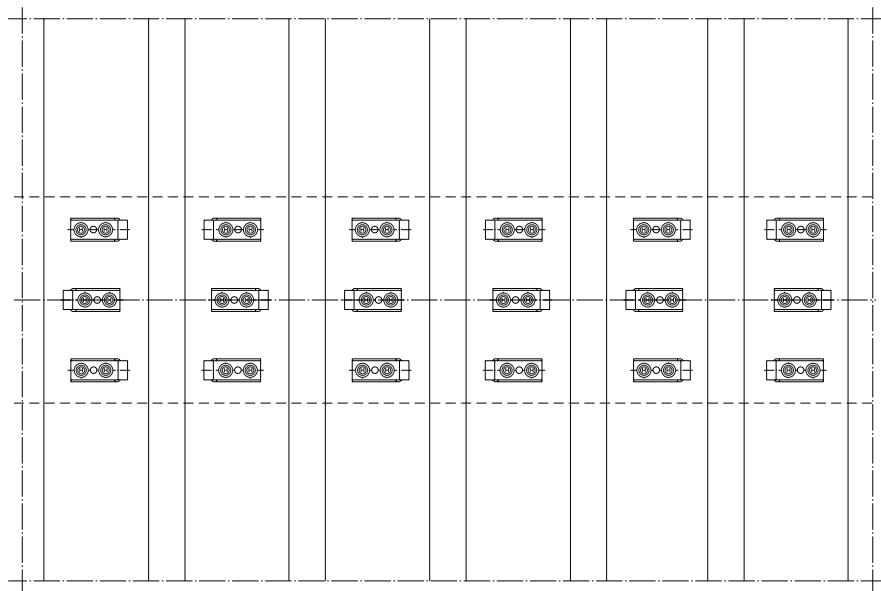
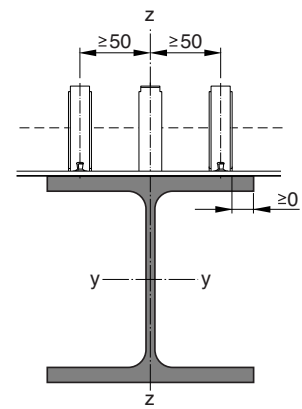

Section A-A

5.5.2 COFRASTRA 40

One X-HVB per rib

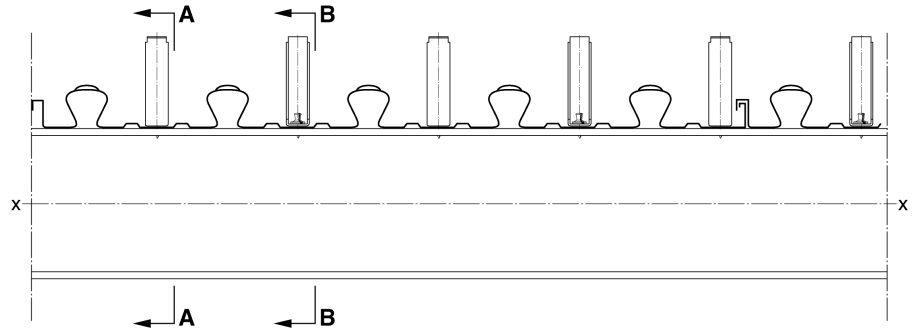
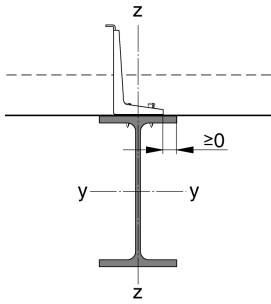

Section B-B

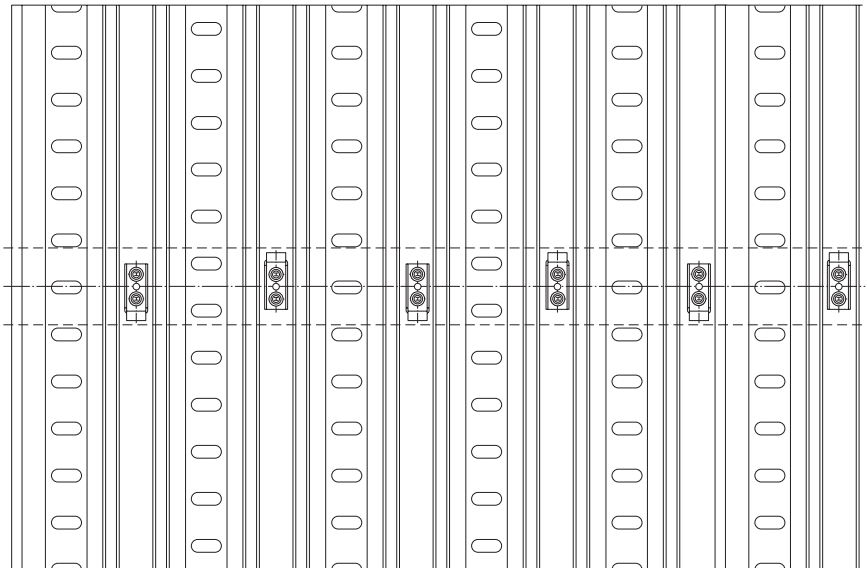
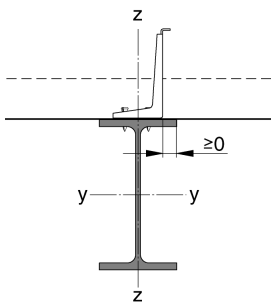

Two X-HVB per rib

Section A-A

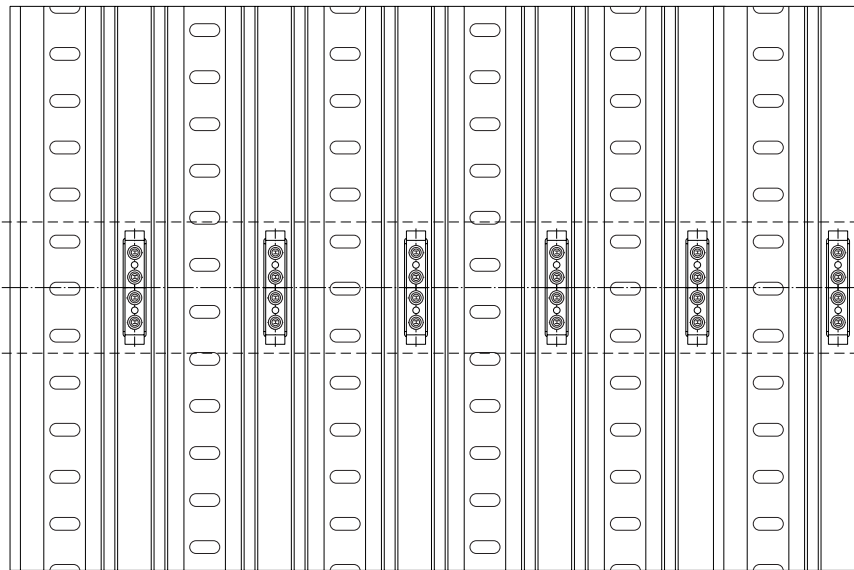
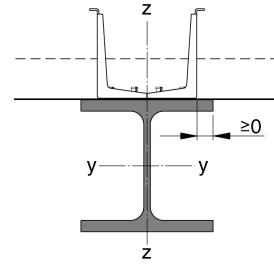
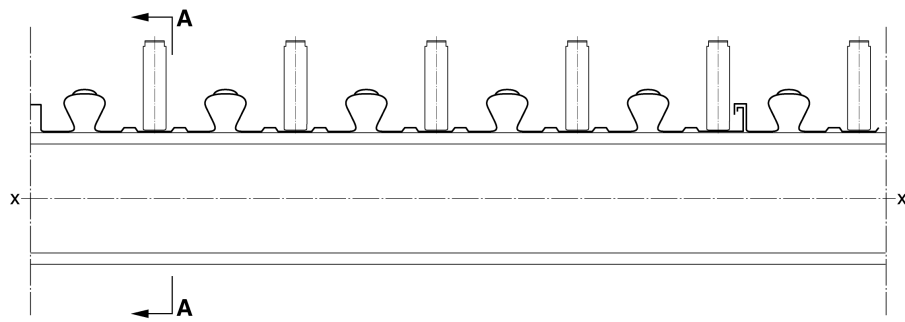

Section A-A

Three X-HVB per rib

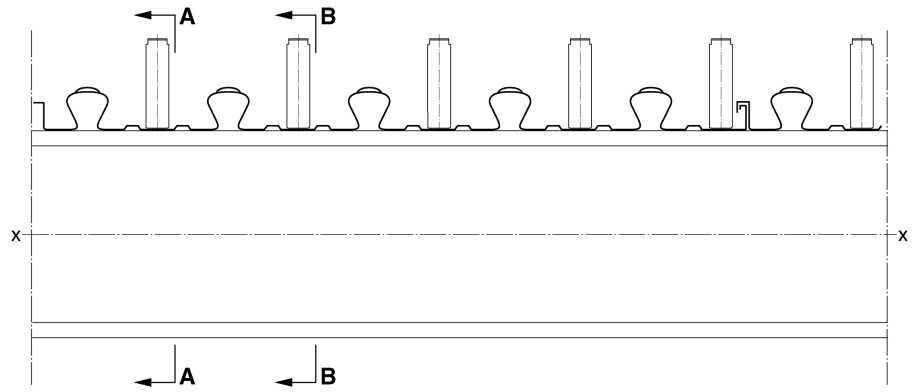
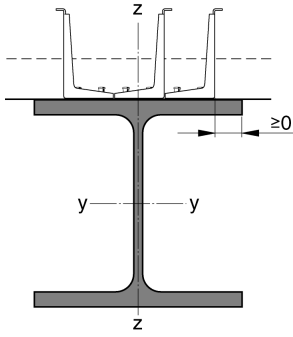

Section B-B

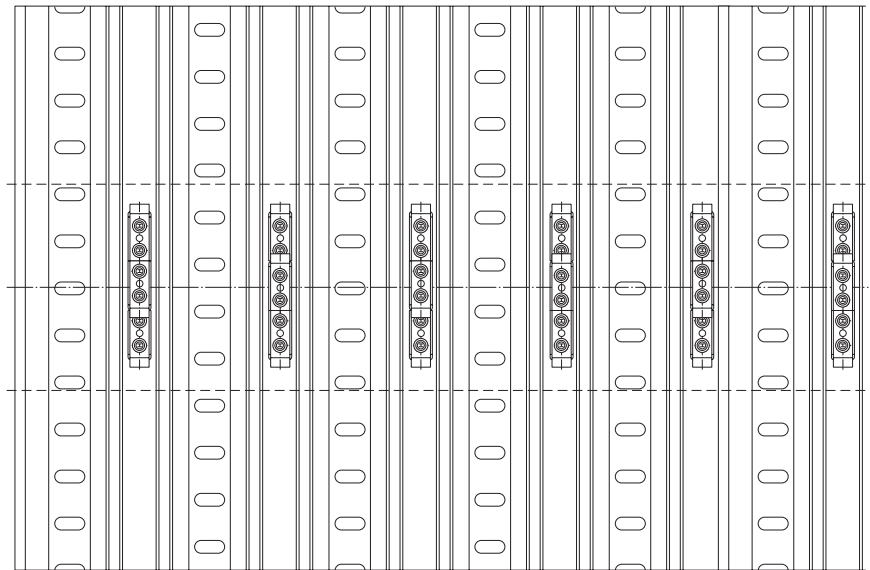
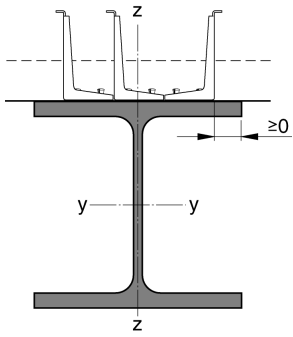

5.5.3 COFRASTRA 70

Two X-HVB per rib

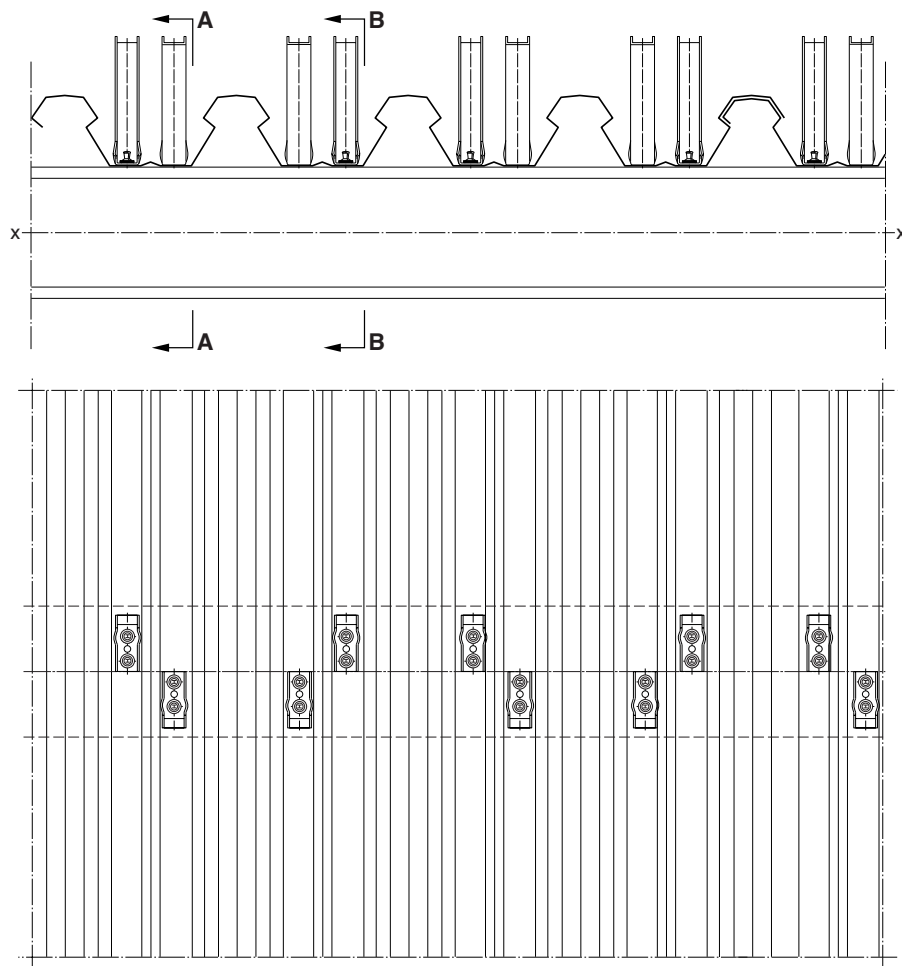

Section A-A

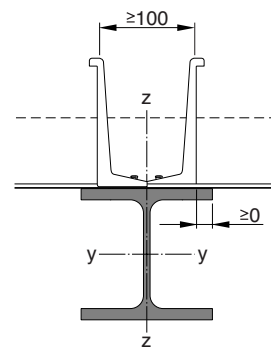

Section B-B

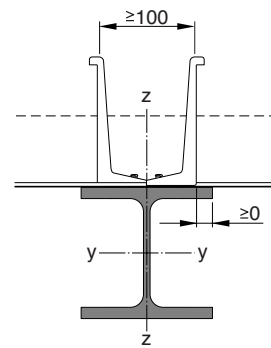

Section A-A

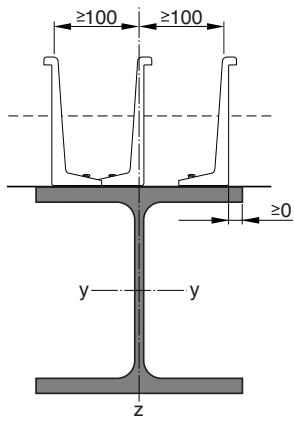

Three X-HVB per rib

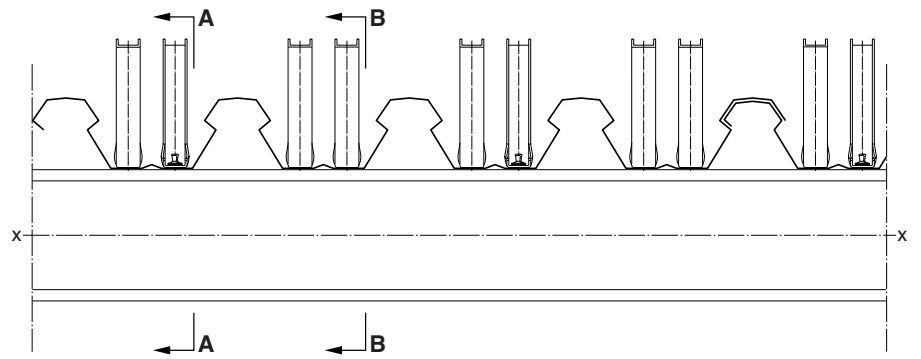

Section B-B

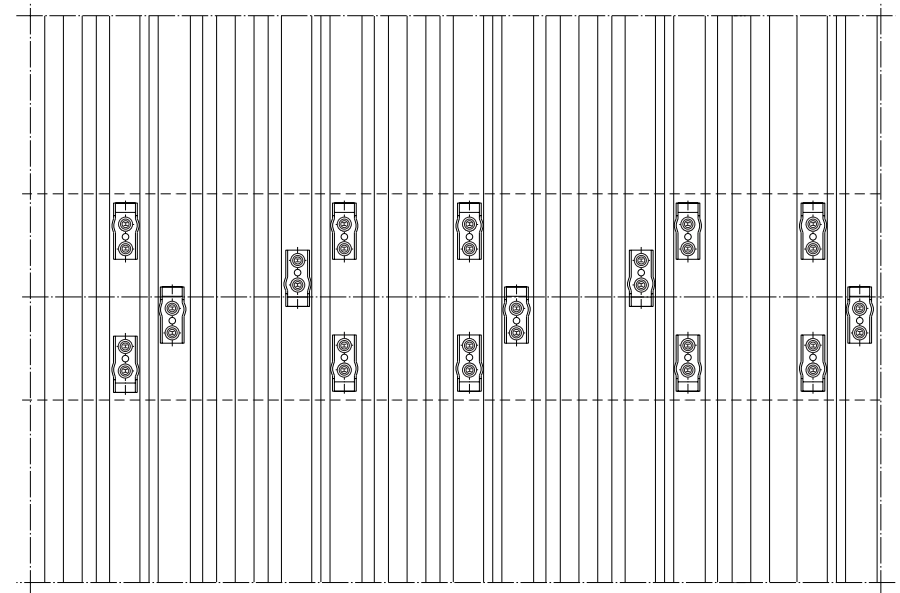
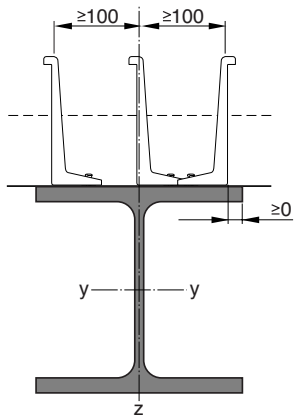

6. Design examples

Substituting specified welded studs with X-HVB

HOLORIB 51 steel decking with the geometry shown in **Figure 50** and ribs transverse to the beam.

This profile is initially designed with holes and one welded shear stud per rib which is to be substituted by the calculated number of X-HVBs.

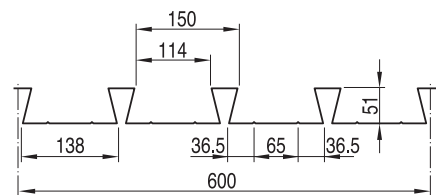

Figure 50: Holorib 51 geometry

The design resistance of the welded shear stud is the minimum value of:

$$P_{rd} = \frac{0.8f_u d^2 / 4}{\gamma_V} = \frac{0.8 \cdot 450 \cdot 19^2 / 4}{1.25} = 81.7 \text{ kN}$$

And

$$P_{rd} = \frac{0.29 \alpha d^2 \sqrt{f_{ck} E_{cm}}}{\gamma_V} = \frac{0.29 \cdot 1 \cdot 19^2 \sqrt{25 \cdot 31 \cdot 10^3}}{1.25} = 73.7 \text{ kN}$$

where

$h_{sc}/d > 4$, therefore $\alpha = 1$ (see section 4.6 Substituting welded shear studs with X-HVB in design)

The reduction factor k_t is given by:

$$k_t = \frac{0.7 b_0}{\sqrt{n_r} h_p} \left(\frac{h_{sc}}{h_p} - 1 \right) = \frac{0.7 \cdot 114}{\sqrt{1} \cdot 51} \left(\frac{100}{51} - 1 \right) = 1.5 \rightarrow 1 \quad (\text{not larger than } 1)$$

However, according to table 6.2 of EC1994-1-1, the maximum value for k_t is 0.75.

$$\text{Hence, } P_{rd} = 0.75 \cdot 73.7 = 55.3 \text{ kN}$$

The shear resistance of X-HVB, assuming the X-HVB 110 is used, is:
 $P_{rd} = 28 \text{ kN}$ (Table 7, view section 4. Shear connector design according to EC4)

The reduction factor, k_t is given by:

- Assuming one shear connector per rib,

$$k_t = \frac{0.7 b_0}{\sqrt{n_r} h_p} \left(\frac{h_{sc}}{h_p} - 1 \right) = \frac{0.7 \cdot 114}{\sqrt{1} \cdot 51} \left(\frac{110}{51} - 1 \right) = 1.81 \rightarrow 1$$

$$P_{rd} = 28 \text{ kN}$$

Comparing the P_{rd} of welded stud and X-HVB, it is clear that more than one X-HVB is required. In this case, we have to recalculate k_t with $n_r = 2$ ($n_r = 2$ for 2 or more X-HVB per rib).

- Two or three shear connectors per rib,

$$k_t = \frac{0.7 b_0}{\sqrt{n_r} h_p} \left(\frac{h_{sc}}{h_p} - 1 \right) = \frac{0.7 \cdot 114}{\sqrt{2} \cdot 51} \left(\frac{110}{51} - 1 \right) = 1.28 \rightarrow 1$$

Hence,

$$P_{rd} = 28 \text{ kN}$$

Number of X-HVB required to substitute a welded stud = $55.3 / 28 = 1.975 = 2$

Accordingly, two X-HVBs are necessary to replace one welded stud per rib in this case.

In many cases, as welded studs have been oversized initially, simple replacement to ensure the same resistance may promote inefficient use or design.

6.1 Hilti support

Hilti provides excellent engineering support and services.

Please contact your local Hilti representatives if you have any queries on the design and installation of X-HVBs.

7. Special considerations

7.1 Fire resistance

The temperature-dependent characteristic shear resistance of X-HVB shear connectors in a solid slab, in the fire situation, should be determined according to the following expression:

$$P_{fi,d} = \frac{k_{u\theta} P_{Rk}}{\gamma_{M,fi}}$$

Where,

P_{Rk} is the characteristic shear resistance of X-HVB, as provided in DFTM (section 4.5).

$\gamma_{M,fi}$ is the partial safety factor for shear resistance for the fire situation. The recommended value for $\gamma_{M,fi}$ is 1.

$k_{u,\theta}$ is the reduction factor for the yield strength of X-HVB, given by:

X-HVB temperature, θ_a	$k_{u\theta,HVB}$
20	1.00
100	1.00
200	1.00
300	0.77
400	0.42
500	0.24
600	0.12
>700	0

Table 12: Reduction factor for the yield strength of X-HVB in DIBt Z-26.4-46

When profiled steel decking is used, the resistance of X-HVB should be further multiplied by the reduction factors which are dependent on decking rib orientation, as present in **4. Shear connector design according to EC4.**

EC4-1-2 states that the temperature of shear connectors during the fire situation should be 80% of the temperature at the top steel beam.

When designing for a fire situation, the total characteristic shear resistance of X-HVBs is compared to the longitudinal shear force acting on the beam with fire loading.

7.2 Rehabilitation

At the University of the German Army in Munich, push-out tests with HVB's have also been carried out in order to investigate the loadbearing capacity of the shear connectors on old wrought iron beams with a view to issuing a specific jobsite approval. The main finding was that for these old beams the standard load data published within the DFTM is valid and can be used for design.

The French Socotec PX 0091/8 approval specifically addresses the use of Hilti X-HVBs in rehabilitation projects. For more details, please refer to the approval.

7.3 Deflection control

If the shear connection is only required for deflection control there is no minimum degree of connection. However, minimum allowable connector spacing applies and the steel beam must have sufficient capacity to carry the self weight and all imposed loads.

8. Project references

Country: Portugal
 City: Lisbon
 Project name: Torre da Agência Europeia da Segurança Marítima no Cais do Sodré
 Builder: Teixeira Duarte / Somague
 Year: 2007

Reasons why X-HVB is used (valid value propositions for the project):

A system of primary beams and secondary beams was adopted.

- On composite secondary beams, shear connectors were installed on site.
- On primary beams, shear connectors were installed in the shop/yard and no welding was done on site.

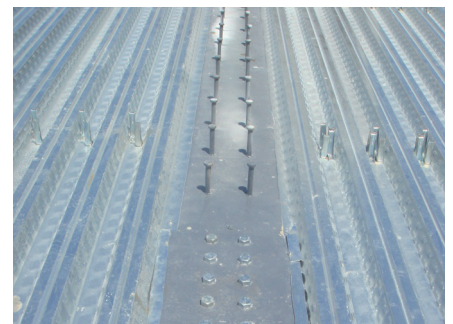
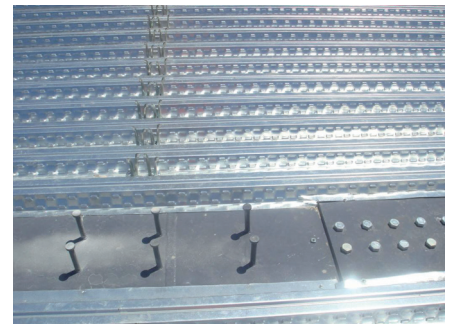

Figure 51: X-HVB application in Portugal

9. References

9.1 Approvals

France:

- SOCOTEC (2012): Cahier des charges des connecteurs en construction neuve. No. PX 0091/7. December 2012.
- SOCOTEC (2012): Cahier des charges d'utilisation en réhabilitation des connecteurs X-HVB, No. PX 0091/8. December 2012.

Germany:

- Deutsches Institute für Bautechnik (2013): Zulassungsbescheid Z-26.4-46: Hilti Schenkeldübel X-HVB als Verbundmittel. October 2013.

Czech Republic:

- Technical and Test Institute for Construction Prague (2011). Spřahovací prvky Hilti pro spřahování ocelobetonových konstrukcí ve stavebnictví. č.070-041312.

Romania:

- Ministerul Dezvoltării Regionale și Administrației Publice Consiliul Tehnic Permanent Pentru Construcții (2013): Procedeu pentru fixarea conectorilor Hilti X-HVB pentru realizarea de elemente structurale mixte pentru construcții. AT 016-01/281-2013.

9.2 Direct Fastening Technology Manual

The Hilti Direct Fastening Technology Manual (DFTM) is intended as a guide on how to use and choose suitable and correct direct fastening solutions for each specific application. The DFTM provides all the technical data necessary for the correct utilization of Hilti's direct fastening products and describes the main principles and techniques that have an influence on direct fastening.

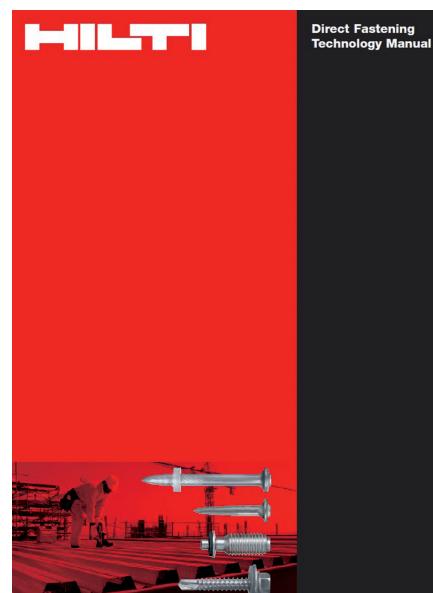

Figure 52: Hilti Direct Fastening Technology Manual

10. Literature and Hilti publications

Neuer Verbunddübel für Konstruktionen mit Stahl/Beton-Verbund, M. Crisinel, D. Clenin, Schweizer Baublatt 77, 9/85 (C4: VI.2.4.4)

Zur Bemessung von Schenkeldübeln, eines neuen Dübels für Verbundkonstruktionen im Hochbau, F. Tschemmerneegg, Bauingenieur 60 (1985) (C4: VI.2.4.5)

The Behaviour and Strength of Steel to Concrete Connection using HVB Shear Connectors (EC4-Design), J.C. Badoux, EPF Lausanne, ICOM 617-4, 2/1984 (C4: VI.2.2.8)

Partial-Interaction Analysis of Composite Beams with Profiled Sheeting and Non-welded Shear Connectors, M. Crisinel, EPF Lausanne, Journal of Constructional Steel Research 15 (1990) 65 – 98 (C4: VI.2.4.11)

Composite beams with profiled-steel sheeting and non-welded shear connectors, D.A.B. Thomas, D.C. O'Leary, Steel Construction Today 1988, 2, 117 - 121

Testing of Continuous Span Composite Slabs with Hibond 55 Profiled Sheeting (HVB 95), B.J. Daniels, M. Crisinel, D.O'Leary, ICOM 229 (C4: VI.2.1.11)

Partial connection of steel and concrete composite beams with HVB shear connectors, K. Peleska, Department of Steel Structures, CVUT Praha, Proceedings of Eurosteel 99 Conference

Powder-actuated fasteners and fastening screws in steel construction, H. Beck, M. Siemers, M. Reuter. Stahlbau-Kalender. Ernst & Sohn (2011).

Hilti. Outperform. Outlast.

Hilti Corporation | 9494 Schaan | Liechtenstein | P +423-234 2111 | F +423-234 2965 | www.hilti.com